



**TRUE NORTH**  
CLASSICAL ACADEMY

# **Incoming Fifth Grade Summer Learning**



# TRUE NORTH

## CLASSICAL ACADEMY

*Timeless Principles: Remarkable Achievement*

June 4, 2026

### Summer Learning Plan

Dear Parents:

It is difficult to believe that summer is here! While we believe that the summer months should be an opportunity for leisure and quality time spent with family, we also believe that a healthy engagement of the mind is necessary to keep the learning of the past year fresh and to help create a bridge for the new learning to come. With that said, we have asked teachers for help in creating the following summer learning plan. The reading plan will include reading one novel and to answer comprehension questions; the math plan will include a math packet and other activities based on your grade level. **Please note that completion of summer work is mandatory. However, also, please note that the summer work is a minimum to be attained; it does not prohibit you from having your child read more books and complete more math. Students will have accessibility to IXL until July 30<sup>th</sup>. We encourage scholars to continue working on lessons throughout the summer.**

### Incoming Fifth-Grade

#### Reading

*Mrs. Frisby and the Rats of Nimh* by Robert C. O'Brian

**Assignment:** Answer the attached comprehension questions.

#### Math

Math Packet Attached

All the above-mentioned books can be purchased on **Amazon** at a very reasonable price. The hope is that your child will enjoy the required book and read much more as well (if possible).

Research has shown that regression of learning during the summer months can, sometimes, account for one-third of learning gains achieved during the school year. Have your child read aloud to you, ask questions as they read, and read to them to model good fluency. Your child should be prepared to discuss the book upon return to school.

Upon returning to school, the summer book will be discussed and the assignment must be turned in. Students will **receive a grade** for the completion of the summer reading and math assignment.

Let me know if you have any questions. Enjoy your summer!!

Warm regards,

True North Administration

### **5<sup>th</sup> Grade Summer Reading Questions**

*Mrs. Frisby and the Rats of Nimh* by Robert C. O'Brian

**Directions: On a separate sheet of lined paper, neatly answer the questions below in complete sentences. You will be graded on neatness and quality of the answers.**

1. An exciting story relies on a crisis to make things more interesting for the reader. What crisis is described in the first chapter?
2. What did Mrs. Frisby assume happened to the animal(s) who stored the food that she found?
3. For each of Mrs. Frisby's children, write one thing which would describe him/her.
  - Teresa:
  - Martin:
  - Cynthia:
  - Timothy
4. Why was it dangerous for Mrs. Frisby to venture too close to the farmhouse and barn?
5. Why does Mrs. Frisby go to see Mr. Ages? What did he advise her?
6. What traumatic event seemed to be the beginning of Timothy's health problems?
7. Although Mr. Ages tells Mrs. Frisby that the medicine will help Timothy recover, what stern warning does he also offer? For how long will this be in effect?

8. Foreshadowing is a literary device where the author provides a hint as to what happens later in the story. How might the warning of Mr. Ages be an example of this?
9. Why was it courageous for Mrs. Frisby to help Jeremy?
10. What unusual things did Mrs. Frisby see in the rats' hideaway?
11. What was Isabella's first impression of Mrs. Frisby?
12. Why was Nicodemus reluctant to allow Mrs. Frisby to help the rats with their plan?
13. In chapter 21, who is talking here? "But what I like best was history. I read about the ancient Egyptians, the Greeks and Romans and the Dark Ages when the old civilizations fell apart. The only people who could read and write were the Monks." Why were the Monks so fascinating to him?

# End-of-Year Review

## Test Prep

### Multiple Choice

Fill in the circle next to the correct answer.

- The digit 9 in 89.4 stands for \_\_\_\_\_. (Lesson 7.2)  
 (A) 9 hundredths                       (B) 9 tenths  
 (C) 9 ones                                       (D) 9 tens
- Find  $9.50 - 2.63$ . (Lesson 8.2)  
 (A) 5.07                                       (B) 5.73  
 (C) 6.67                                       (D) 6.87
- The product of 9 and \_\_\_\_\_ is 1,107. (Lesson 3.1)  
 (A) 123     (B) 1,098  
 (C) 1,116     (D) 9,963
- The table shows the number of fruits and biscuits a group of students have. Some numbers in the table are missing. Use the information in the table to answer the question. (Lesson 4.1)

Name	Number of Fruits	Number of Biscuits	Total
Annabel	25	34	59
Mandy	12	26	38
Crystal		17	

The total number of fruits and biscuits is 120. How many fruits does Crystal have?

- 
- (A) 6
- 
- (B) 23
- 
- 
- (C) 37
- 
- (D) 97



8.  $4\frac{3}{5} =$  \_\_\_\_\_ (Lesson 6.3)

(A)  $\frac{12}{5}$

(B)  $\frac{20}{5}$

(C)  $\frac{23}{5}$

(D)  $\frac{43}{5}$

9. Which of the shaded parts represents  $\frac{4}{5}$  of a set? (Lesson 6.7)

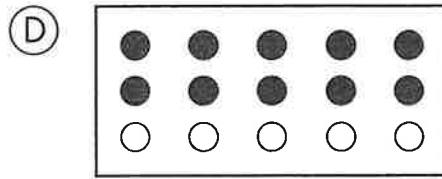
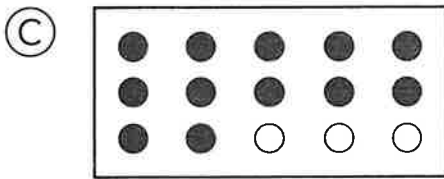
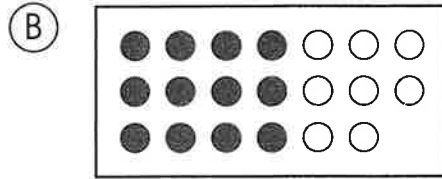
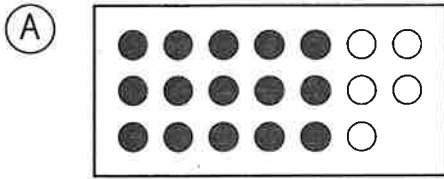

10.

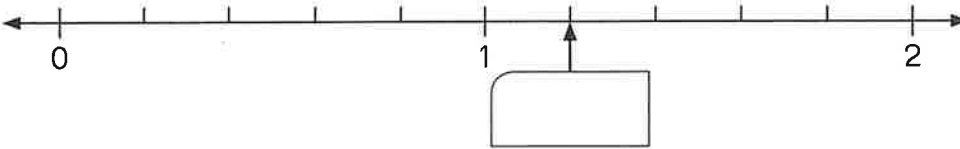

The arrow is pointing at \_\_\_\_\_. (Lesson 7.1)

(A) 0

(B) 1.2

(C) 1.3

(D) 4

11. Ava's mass is 45.0 kilograms when rounded to 1 decimal place. What is her least possible mass? (Lesson 7.4)

- (A) 45.01 kilograms      (B) 44.95 kilograms  
(C) 44.99 kilograms      (D) 44.55 kilograms

12. 0.55 is not equal to \_\_\_\_\_. (Lesson 7.5)

- (A)  $\frac{11}{20}$       (B)  $\frac{55}{100}$   
(C)  $\frac{550}{1,000}$       (D)  $\frac{55}{10}$

13.  $4.6 - 0.46$  is equal to \_\_\_\_\_. (Lesson 8.2)

- (A) 0      (B) 4.14  
(C) 4.20      (D) 4.26

14. Which of these angles is an acute angle? (Lesson 9.1)

(A)

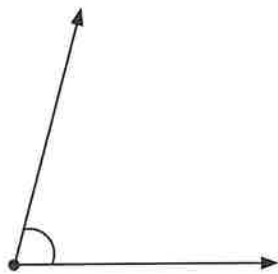

(B)

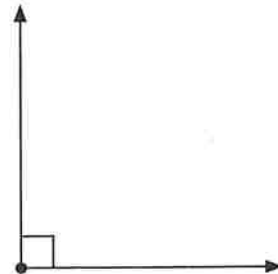

(C)

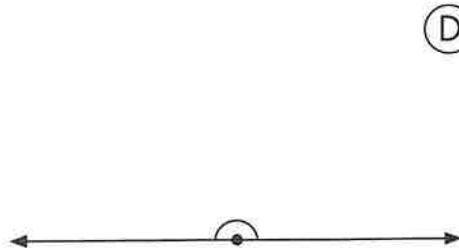

(D)

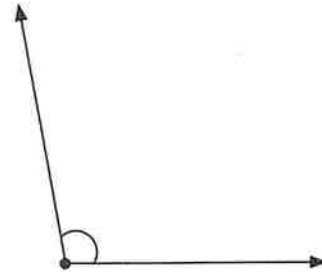

15.

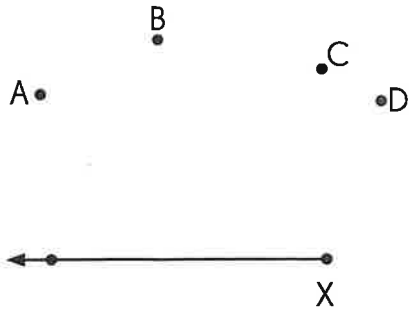

Sam needs to draw an angle of  $125^\circ$  from point  $X$ .  
He must join point  $X$  to point \_\_\_\_\_. (Lesson 9.2)

- (A)  $A$                       (B)  $B$   
(C)  $C$                       (D)  $D$

16. Refer to the figure to answer Exercises 15 and 16.

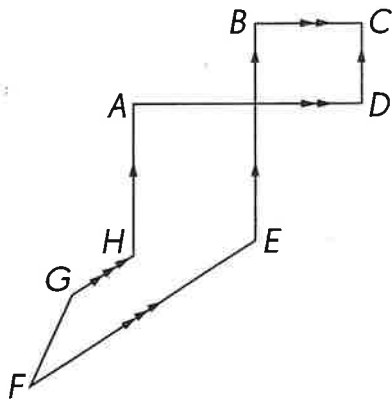

Which line segment is perpendicular to  $\overline{AH}$ ? (Lesson 10.1)

- (A)  $HG$                       (B)  $BE$   
(C)  $FE$                       (D)  $AD$

17. Which line segment is parallel to  $\overline{CD}$ ? (Lesson 10.2)

- (A)  $AD$                       (B)  $GH$   
(C)  $BE$                       (D)  $FG$

18. In the square below, find the measure of  $\angle a$ . (Lesson 11.2)

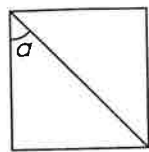

- (A)  $30^\circ$                       (B)  $45^\circ$   
(C)  $60^\circ$                       (D)  $90^\circ$
19. The perimeter of a rectangle is 24 centimeters.  
The length of one of its sides is 5 centimeters.  
What is the area? (Lesson 12.1)

- (A)  $7 \text{ cm}^2$                       (B)  $14 \text{ cm}^2$   
(C)  $35 \text{ cm}^2$                       (D)  $49 \text{ cm}^2$

20. All line segments on the figure meet at right angles.  
Find  $EF$ . (Lesson 12.1)

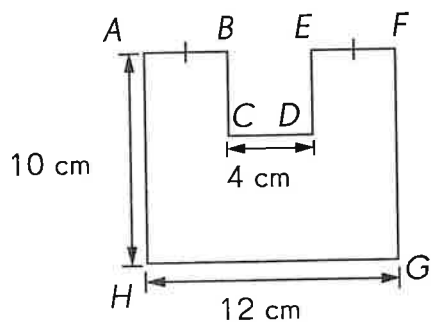

- (A) 4 cm                              (B) 6 cm  
(C) 8 cm                              (D) 10 cm

21. Which pair of figures are symmetric? (Lesson 13.1)

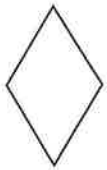

A

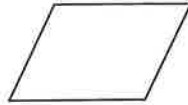

B

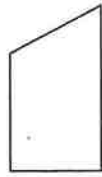

C



D

(A) A and B

(B) B and C

(C) C and D

(D) D and A

22. What is the repeated shape used in the tessellation? (Lesson 14.1)

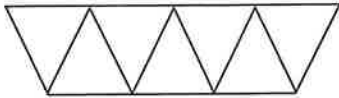

23. Which of these shapes has rotational symmetry? (Lesson 13.2)

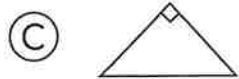
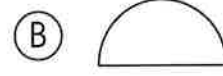

24. This shape can be tessellated by \_\_\_\_\_. (Lesson 14.2)

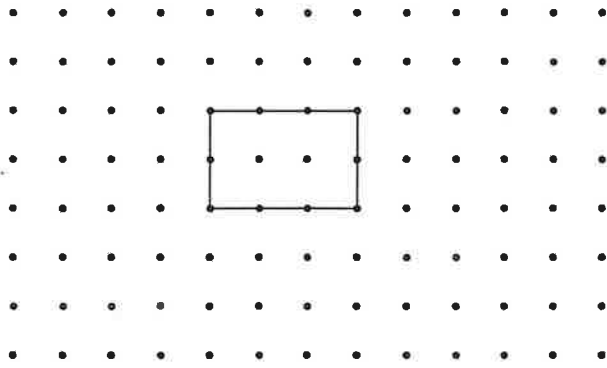

- (A) sliding                       (B) rotation  
 (C) flipping                       (D) All of the above

25.

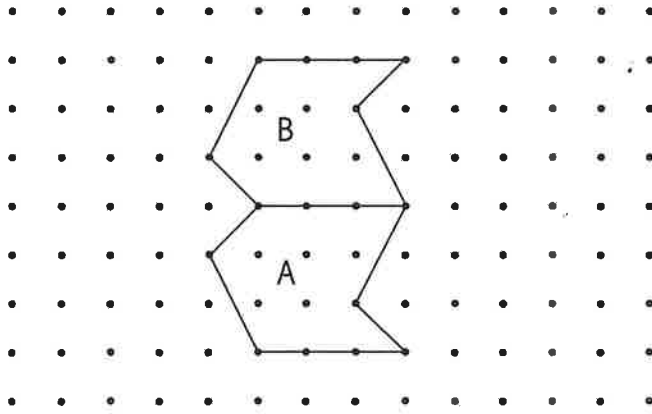

From position A to B, the unit shape has been \_\_\_\_\_.

- (A) slid                               (B) rotated  
 (C) flipped                           (D) none of the above

**Short Answer**

**Read each question carefully. Write your answers in the space given.  
Give your answers in the correct units.**

- 26.** I am a number between 30 and 50. I am a multiple of 8.  
My greatest common factor with 25 is 5.  
What number am I? (*Lessons 2.2 and 2.3*)

\_\_\_\_\_

- 27.** The table shows the number of marbles Anthony and Michelle have.  
Complete the table and answer the questions. (*Lesson 4.1*)

	Red Marbles	Blue Marbles	Total
Anthony	18	26	
Michelle	37		61

- a.** What was the total number of red marbles?

\_\_\_\_\_

- b.** What fraction of the total number of marbles were blue?

\_\_\_\_\_

28. The graph shows the amount of water used by the residents of an apartment block over a morning. (Lesson 4.3)

**Amount of Water used by the Residents**

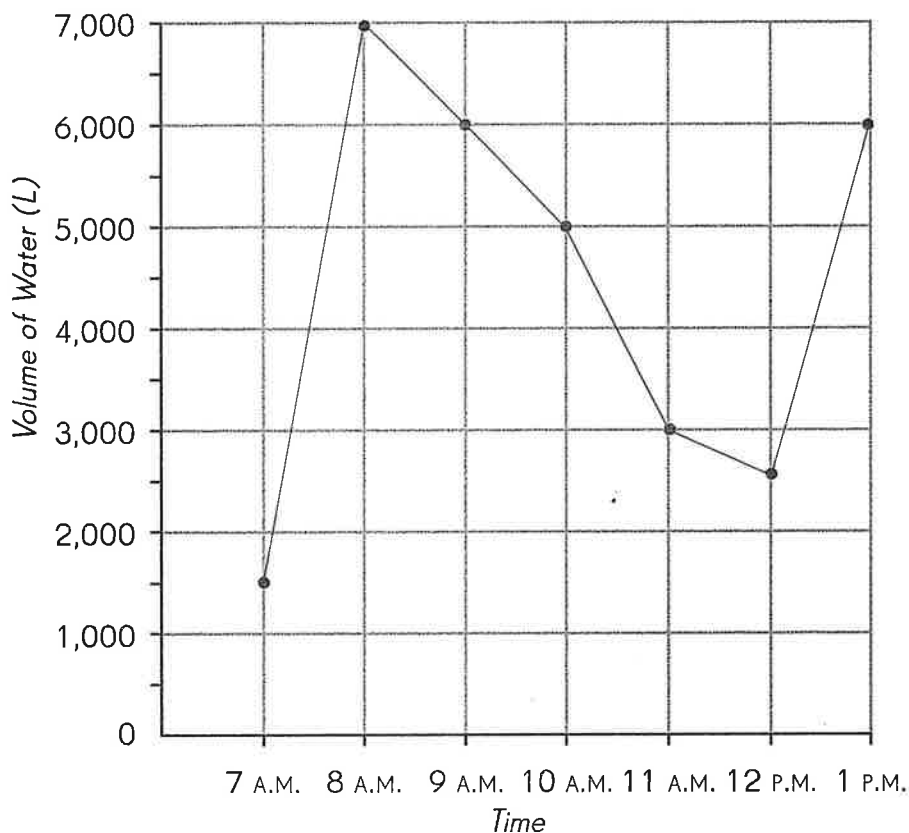

- a. At which two times was the same amount of water used?
- b. At what time was the amount of water used twice that used at noon?
29. A bag has 5 pink balls, 8 yellow balls, and 4 blue balls. What is the probability of drawing a pink ball from the bag? (Lesson 5.5)
30. What is  $\frac{7}{12} - \frac{2}{6}$ ? Express your answer in simplest form. (Lesson 6.2)

31. Express  $\frac{30}{7}$  as a mixed number. (Lesson 6.5)

\_\_\_\_\_

32. Find the difference between  $\frac{5}{8}$  and 3. (Lesson 6.6)

\_\_\_\_\_

33. How many grey squares must be replaced by white squares so that  $\frac{2}{3}$  of the total number of squares are grey? (Lesson 6.7)

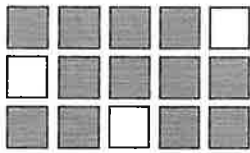

\_\_\_\_\_

34. What is the number in the box? (Lesson 7.2)

$$6.34 = 6 + 0.3 + \boxed{\phantom{00}}$$

\_\_\_\_\_

35. Li Li is 1.85 meters tall. Round her height to the nearest tenth of a meter. (Lesson 7.4)

\_\_\_\_\_

36. Express  $5\frac{6}{25}$  as a decimal. (Lesson 7.5)

\_\_\_\_\_

37. Draw and label a line segment  $BC$  such that the measure of angle  $ABC$  is  $167^\circ$ . Line segment  $AB$  is given. (Lesson 9.2)



38. Draw a line segment perpendicular to  $AB$  through point  $O$ . (Lesson 10.1)



39. Draw a line parallel to  $\overleftrightarrow{CD}$  passing through point  $X$ . (Lesson 10.2)

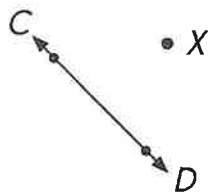

40.  $AB$  is a vertical line segment and  $BC$  is a horizontal line segment. Find the measure of  $\angle ABC$ . (Lesson 10.3)

- 41.** Look at the figure below to answer the question. (Lesson 12.3)

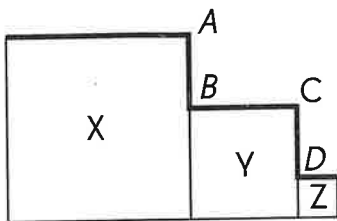

X, Y, and Z are squares. The length of each side of X is 5 centimeters and the length of each side of Y is 3 centimeters.  $AB = CD$ . Find the total length of the thick lines in the figure.

- 42.** Shade some squares and half-squares to make a symmetric pattern in the figure. (Lesson 13.3)

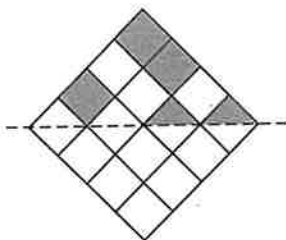

- 43.** In the tessellation below, the unit shape is . Extend the tessellation in the space provided by adding four more unit shapes. (Lesson 14.2)

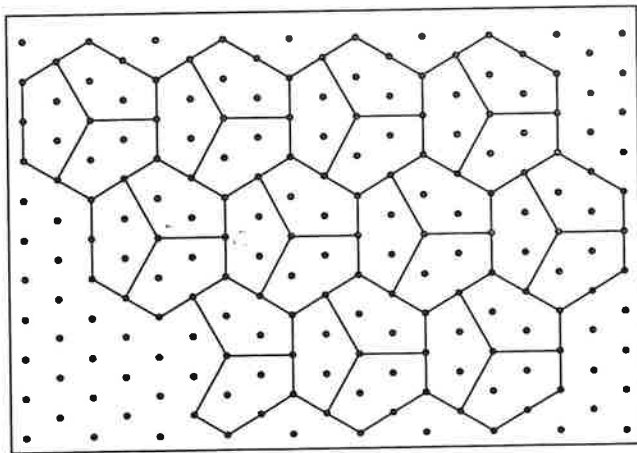

44. Complete the tessellation by adding three more unit shapes. (Lesson 14.2)

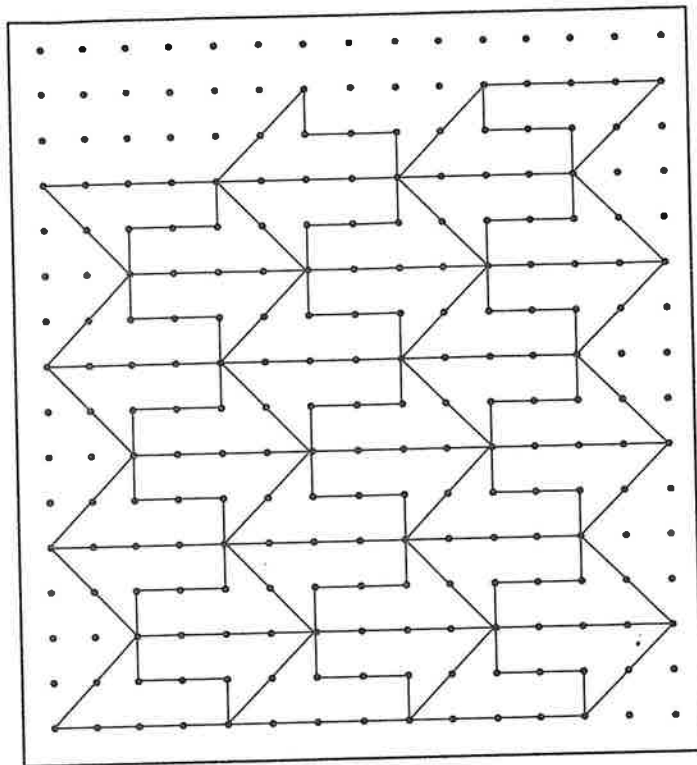

45. Complete the figure so that it has rotational symmetry about point O. (Lesson 13.3)

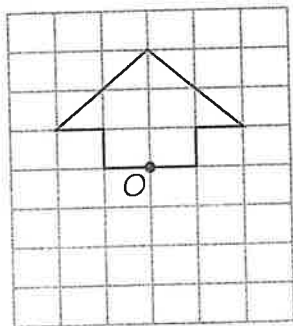

46. a. Does the word 

N	O
---	---

 have rotational symmetry? (Lesson 13.3)

- b. Fill in the box with a letter so that 

N	O	
---	---	--

 will have rotational symmetry. (Lesson 13.3)

**Extended Response****Solve. Show your work.**

- 47.** Jane used  $\frac{1}{4}$  of the flour to make biscuits.  
She used  $\frac{1}{2}$  of the flour to bake a cake.  
What fraction of the flour was left?
- 48.** Mr. Lim has some savings. If he gives \$40 to one brother, he will have \$6,145 left. But he decides to give all his savings to his 5 brothers equally.  
How much will each brother get?
- 49.** Rita bought fabric and ribbon from a store. The ribbon cost \$18.50.  
Rita paid the cashier \$50.00 and received change of \$5.25.  
How much did the fabric cost?

- 50.** The area of a rectangle is 98 square centimeters, and its width is 7 centimeters. Find the length.

- 51.** Richard planted some grass on a rectangular plot of land which measures 12 meters by 8 meters. He left a margin of 0.5 meters around the grass, as shown in the figure below. Find the area of land covered by grass. (Lesson 12.4)

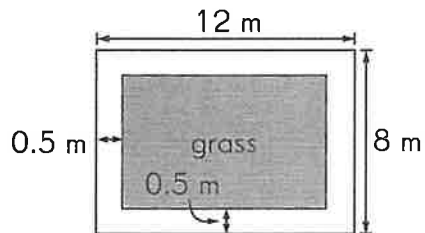

## The Declaration of Independence

### **The Declaration of Independence, by Thomas Jefferson**

When in the Course of human events, / it becomes necessary for one people to dissolve the political bands which have connected them with another, / and to assume among the powers of the earth, / the separate and equal station to which the Laws of Nature and of Nature's God entitle them, / a decent respect to the opinions of mankind / requires that they should declare the causes which impel them to the separation.

We hold these truths to be self-evident, / that all men are created equal, / that they are endowed by their Creator / with certain unalienable Rights, / **that among these are Life, / Liberty / and the pursuit of Happiness.**

That to secure these rights, / Governments are instituted among Men, / deriving their just powers from the consent of the governed, / That whenever any Form of Government becomes destructive of these ends, / **it is the Right of the People to alter or to abolish it,** / and to institute new Government, / laying its foundation on such principles and organizing its powers in such form, / as to them shall seem most likely to effect their **Safety and Happiness.**

Prudence, indeed, will dictate that Governments long established should not be changed for light and transient causes; / and accordingly all experience hath shewn, / that mankind are more disposed to **suffer, while evils are sufferable,** / than to right themselves by abolishing the forms to which they are accustomed.

But when a long train of abuses and usurpations, / pursuing invariably the same Object evinces a design to reduce them under absolute Despotism, / **it is their right, / it is their duty, / to throw off such Government,** / and to provide new Guards for their future security.